



I Applications

The Hyginox SH pump is a centrifugal pump manufactured in stainless steel with steel lantern.

This pump is specially designed to meet the requirements of applications such as filtering, bottling, CIP supply, and auxiliary services in the chemical industry.

I Operating principles

Housed inside the casing, the impeller rotates in conjunction with the pump shaft. With this arrangement, the impeller blades convey energy to the fluid in the form of kinetic energy and pressure energy.

This pump is not reversible by simple reversal of the direction of rotation. The direction of rotation is clockwise when the pump is viewed from the rear side of the motor.

I Design and features

Casing manufactured with cold-formed plate.

DIN connections (standard).

Open impeller manufactured with stainless steel investment casting technology.

Mechanical seal according to DIN 24960 L1K.

Pump certified according to 3A sanitary standards.

Motor according to IEC B35 standards.

IEC B35 motors (B34 for SH-15), IP55, F-class insulation.

Open impeller

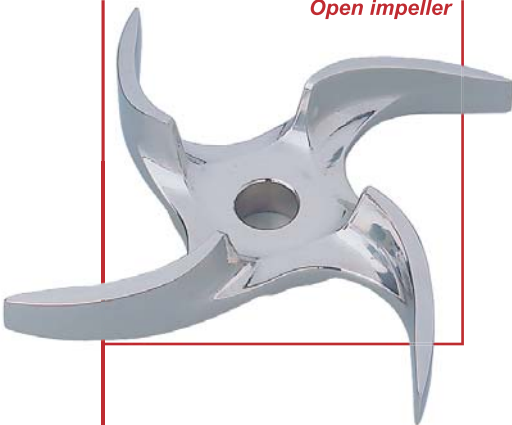

I Materials

Parts in contact with pumped media:

Gaskets (standard)

Mechanical seal (standard)

Lantern

Inside surface finishing

Outside surface finishing

AISI 316L

EPDM (FDA)

C/SiC/EPDM

GG-15

Ra < 0.8 μm

Mirror polished

I Options

Seal in C/St.St and SiC/SiC

Bareshaft construction for models SH-35 / 38.

Gaskets in FPM (Vitor®) and PTFE

Self-priming casing

Drainage connection

Connections: Clamp, SMS, RJT...

Motors with additional protection

Switchboard trolley.

AISI 304 shroud and platen

Stainless steel shroud

AISI 304 legs



I Technical specifications

Max.flow	150 m ³ /h / 660 GPM
Max.head	100 mcl / 328 ft
Max.suction pressure	4 bar / 58 PSI
Max.working temp.	120 °C / 248°F
Max.speed	3500 min ⁻¹

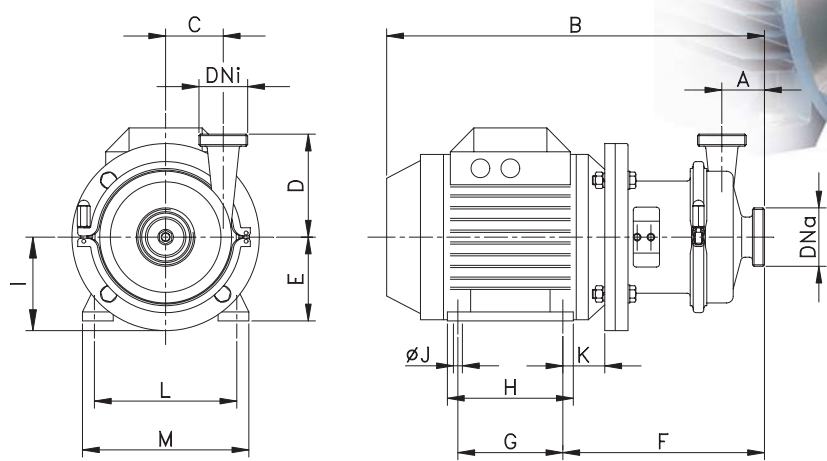
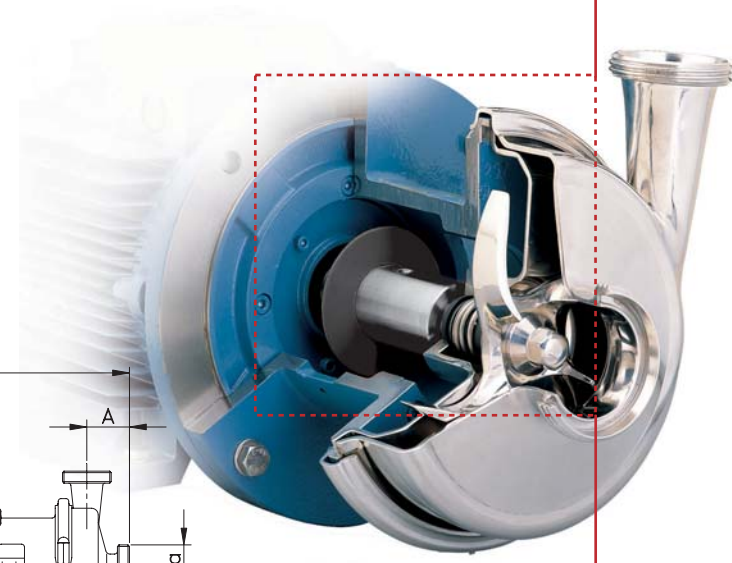

TYPE	Motor Size	[kW]		DNa	DNi	A	B	C	D	E	F	G	H	I	ØJ	K	L	M											
		2900 min ⁻¹	1450 min ⁻¹																										
SH - 15	A	71	0,37	40	32	55	395	55	100	71	230	90	112	85	7	38	112	135											
			0,55																1 ½"	1 ½"									
SH - 20	B	80	1,1	50	40	55	415	74	140	80	401	100	125	105	9	40	125	153											
	C	90S	1,5																2"	1 ½"	455	100	150	10	46	140	170		
		90L	2,2																			125							
SH - 26	B	80		65	50	55	425	72	150	8	240	100	125	105	9	40	125	153											
	E	100	3																3"	2"	510	100	172	125	12	50	160	197	
		112	4																		540	112	168			57	190	222	
	F	132	5,5																		645	132	168	150		73	216	262	
SH - 28	B	80	1,1	40	40	65	420	107	165	80	40	100	125	140	9	40	125	153											
	C	90S	1,1																1 ½"	1 ½"	455	90	150	10	46	140	170		
		90L	2,2																			125							
	E	100	3																		505	100	172		12	50	160	197	
		112	4																		535	112	168			57	190	222	
	F	132	5,5																		640	132	168	150		73	216	262	
SH - 35	C	90L		65	50	75	470	104	175	90	255	125	150	140	10	46	140	170											
	F	132	5,5-9																3"	2"	655	132	140	212	150	12	73	216	262
	G	160M	11																		745	160	210	264	175	14	88	254	302
SH - 38	C	90L		100	65	75	470	98	180	90	256	125	150	140	10	46	140	170											
	E	100																	4"	3"	520	100	172	140	12	50	160	197	
		112	2,2-3																		550	112	168			57	190	222	
			4																		550								
	G	160M	11-15																		745	160	210	264	175	14	88	254	302
		160L	18,5																		790	160	254	309		15	100	279	340
	H	180M	22																		845	180	386	241	323				
J	200	30			910	200	428	305	365	200	19	113	318	406															

Dimensions with DIN 11851 connections

